

Magnetic Field Meter 1000

Operator's Manual

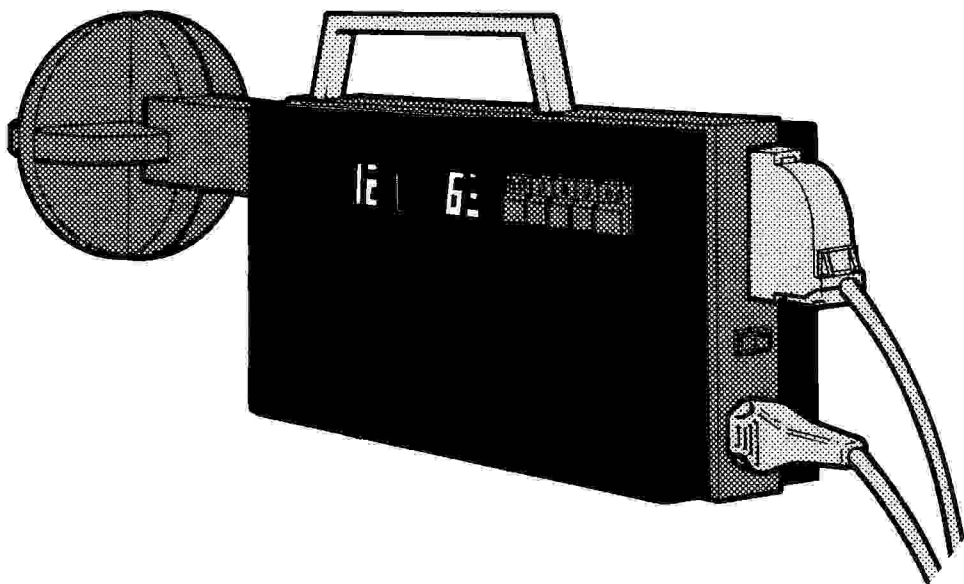

ab *combinova*

ab* *combinova

MFM 1000

**OPERATOR'S
MANUAL**

Since product development and improvement is a continual process, Combinova AB reserves the right to make any changes in the specification without notice.

CONTENTS

		Page
SECTION 1	INTRODUCTION	
	1.1 Measurement Procedure	1.2
	1.2 Definitions	1.2
	1.3 General Principles of Measurement	1.2
SECTION 2	UNPACKING AND INSPECTION	
SECTION 3	SETTING UP	
	3.1 A – Language Selection	3.2
	3.2 B & C – Printer Set-up	3.2
	3.3 D – Measurement Mode	3.3
	3.4 Mains Voltage	3.6
	3.5 Loudspeaker Volume	3.6
	3.6 Serial Interface	3.6
SECTION 4	OPERATING INSTRUCTIONS	
	4.1 Operating Panel	4.1
	4.2 Background Noise	4.2
	4.3 Measurement Tools	4.3
	4.4 Single Point Measurement	4.3
	4.5 Multiple Point Measurement	4.3
	4.6 Continuous Measurement	4.4
	4.7 Printer Operation	4.4
	4.8 Remote Control	4.8

		/continued
		Page
SECTION 5	TECHNICAL DESCRIPTION	
5.1	Antenna	5.1
5.2	Electronics	5.3
5.3	Measurement Principle	5.3
5.4	Specifications	5.5
SECTION 6	ERROR CODES	
6.1	Measurement Errors	6.1
6.2	Operational Errors	6.2
6.3	Memory Errors	6.2
6.4	Software Errors	6.3
 WARRANTY CARD		
 QUICK REFERENCE GUIDE		

SECTION 1

INTRODUCTION

The Magnetic Field Meter 1000 (MFM 1000) is designed to measure and record the magnetic field emitted by a Visual Display Unit (VDU). As the resolution and refresh rates of new types of VDU's increase, the magnetic field produced increases as well. This has led to demands that the magnetic field should be kept to a minimum. However, modifying the VDU to minimize the magnetic field requires an accurate and quick means of measuring the field. The MFM 1000 has been developed specifically for this purpose.

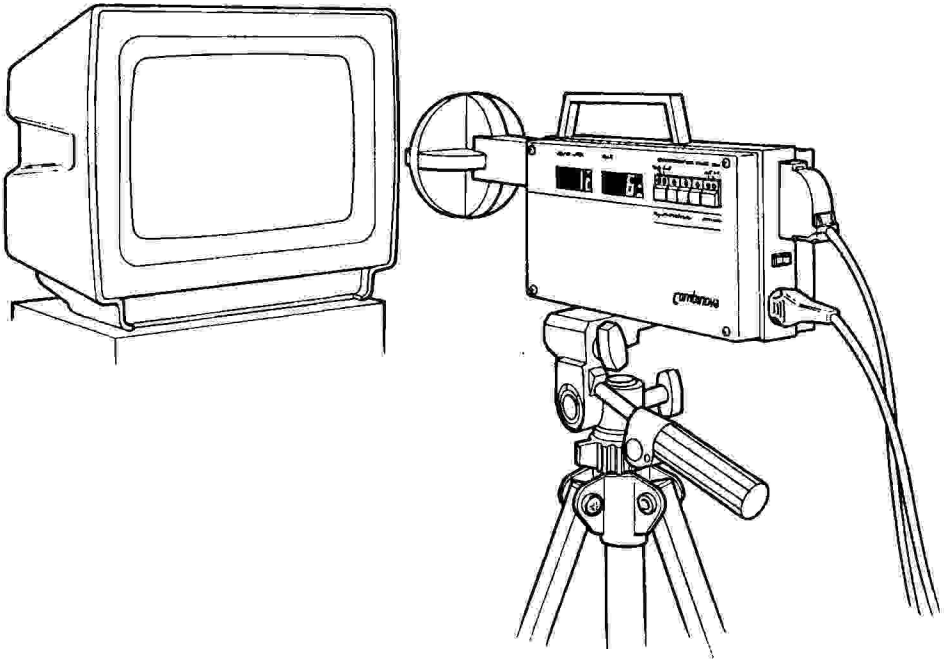

Fig. 1.1 View of Equipment

1.1 Measurement Procedure

Measurement recommendations covering all aspects of cathode-ray type VDU's have been produced by the National Board of Measurement and Testing (MPR) in Sweden. The MFM 1000 has been designed to comply with these recommendations and to fulfil the measurement equipment requirements. Because the MPR recommendations are continually evolving, you should ensure that the latest version of the MFM 1000 is being used. Contact your distributor if you wish to upgrade your MFM 1000 to the latest version.

The measurement procedure for measurements according to the MPR recommendations is detailed in a separate application note.

1.2 Definitions

Magnetic field is defined as the magnetic flux density and the unit of measurement is Tesla (T). The magnetic field from VDU's is normally quoted in nT. Induction is defined as the time derivative of magnetic flux density. The unit of measurement is T/s. Induction from VDUs is normally quoted in mT/s.

1.3 General Principles of Measurements

The instrument uses a system of three perpendicularly aligned coils, which allows measurements simultaneously in all directions. The signals which are induced in the coils correspond to an induction of:

$$\left(\frac{dB_{x,y,z}}{dt}\right)_{\text{peak}} \quad (\text{where } x, y, z \text{ are the signals from each of the three separate coils})$$

and are amplified and filtered according to the recommended specification. To obtain the overall flux density B_{xyz} , the signals are individually integrated with time. After a sample-and-hold stage all signals are analogue-to-digital converted.

The total magnetic field (B_{peak} or B_{rms}) and induction (dB/dt) are calculated from the values of the three coils according to the following formulae:

$$\left(\frac{dB}{dt}\right)_{\text{peak}} = \sqrt{\left(\frac{dB_x}{dt}\right)_{\text{peak}}^2 + \left(\frac{dB_y}{dt}\right)_{\text{peak}}^2 + \left(\frac{dB_z}{dt}\right)_{\text{peak}}^2}$$

$$B_{\text{peak}} = \max. \text{ of set } \left[\sqrt{(B_{x_n}^2 + B_{y_n}^2 + B_{z_n}^2)} \right]_{n=1}^N$$

$$B_{\text{rms}} = \frac{\sqrt{\sum_{n=1}^N B_{x_n}^2 + \sum_{n=1}^N B_{y_n}^2 + \sum_{n=1}^N B_{z_n}^2}}{N}$$

where

N = Number of samples calculated from the frequency of the measured signal.

When measuring the B_{rms} value, in external sync mode, the dominant frequency ($15\text{kHz} < f_0 < 120\text{kHz}$) is calculated and presented. In internal sync mode, random sampling is used and frequency is not displayed.

Measurements can be made for all signal frequencies between 2kHz and 400kHz in a wide band mode, which gives high stability and accuracy without having to re-calibrate the instrument. To ensure that the instrument is working correctly a test instrument, the MFG 250 Helmholtz coil signal generator can be used.

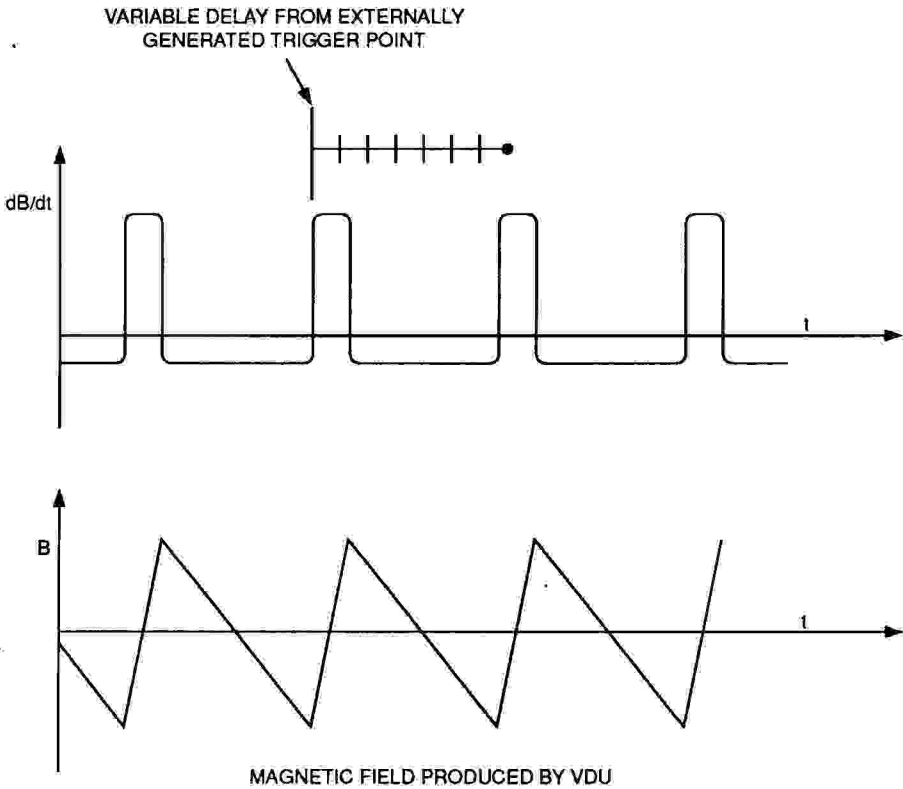

Fig. 1.2 Principle of Operation

SECTION 2

UNPACKING AND INSPECTION

Before unpacking the MFM 1000 inspect the transport box for any damage caused during transit. If damage has occurred this should be taken up with the shipping company.

The items delivered as standard are:

- MFM 1000
- Power Cable (2.5 metres)
- Additional Fuses
- Distance Measurement Tool for MPR measurement
- Operator's Manual.
- Tripod
- Transportation Case
- Turntable.

IMPORTANT!

Complete the warranty form and return a copy to Combinova AB. The warranty is only valid when the warranty copy has been sent.

Familiarise yourself with the MFM 1000 and its accessories by reading this manual before you switch on the instrument.

Before attempting to switch on the MFM 1000 make certain that the mains voltage setting is correct (see Section 3).

This manual contains all information necessary to operate the instrument. If problems arise when operating the MFM 1000, contact Combinova AB for assistance: (Sweden) 08 733 93 10, fax (0)8 29 59 85).

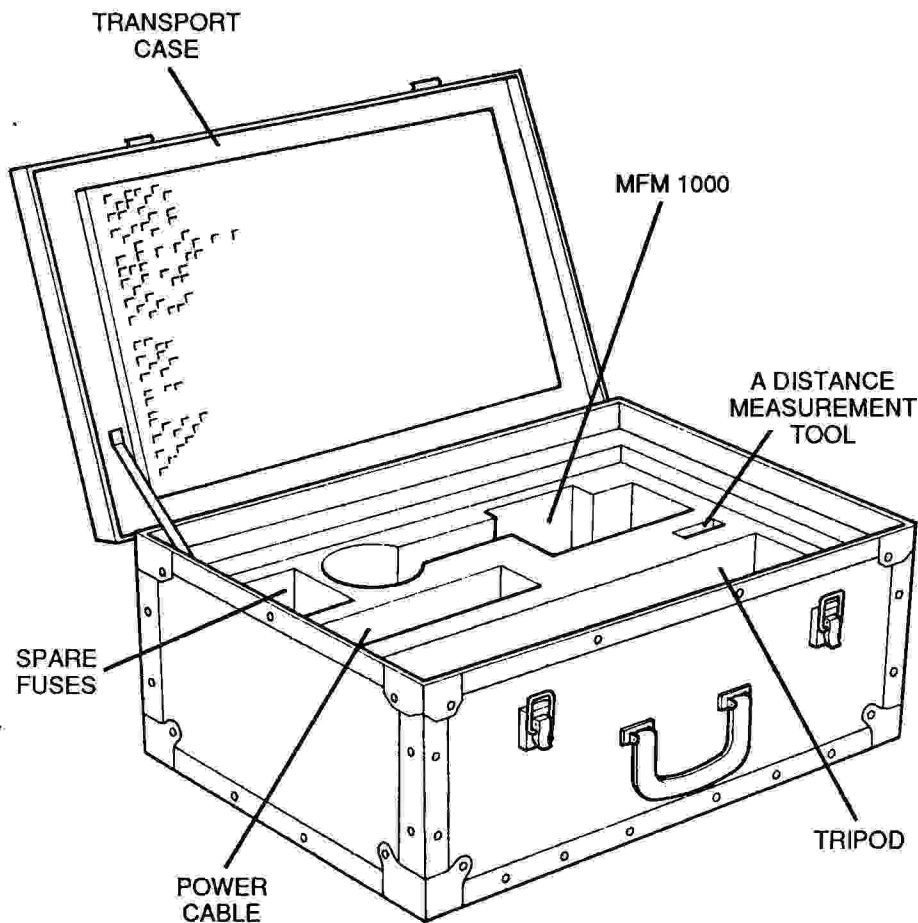

Fig. 2.1 Unpacking the MFM 1000

SECTION 3

SETTING UP

A special set-up mode is included in the MFM 1000 software to allow a number of parameters which affect the function of the MFM 1000 to be set-up.

To enter the set-up mode hold the START and SYNC keys depressed during power up and the initial test sequence.

The left-hand display will respond with:

- X.Y -

Where X is the program version number and Y is a program release number.

The right-hand display will respond with four digits in the following positions:

A B C D

Each digit represents a separate programming function. The selected digit flashes and its value can be altered by pressing the START key. When the value has been selected move to the next digit by pressing the SYNC key. When all parameters have been set to the desired settings press the SYNC key twice to enter and store them into the MFM 1000. The parameter settings are now written into a non-volatile memory and therefore remain even when the instrument is switched off.

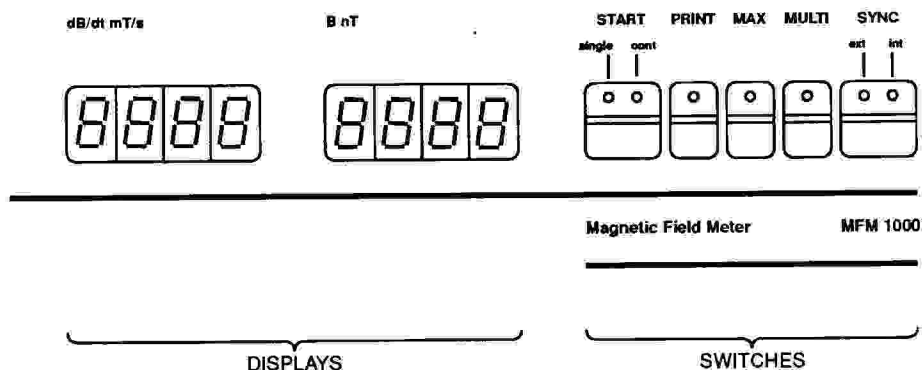

Fig. 3.1 Operator's Panel

3.1 A – Language Selection

The first digit (A) is used to select the language used in the pre-programmed print formats.

- 0 = English
- 1 = Swedish

The default setting is 0 (English).

3.2 B & C – Printer Set-up

The second digit (B) is used to select printer format.

- 0 = No printer used
- 1 = 48 lines/page
- 2 = 66 lines/page
- 3 = 70 lines/page
- 4 = 72 lines/page

The default setting is 0 (no printer used). Note that this setting should be used if a printer is not connected to the MFM 1000.

The third digit (C) is used to select printer baud rate.

- 0 = 300 baud
- 1 = 600 baud
- 2 = 1200 baud
- 3 = 2400 baud
- 4 = 4800 baud

The default setting is 2 (1200 baud). The output to the printer is 8 bit data, with 2 stop bits and no parity bit.

3.3 D – Measurement Mode

The fourth digit is used to select different measurement modes.

- 0 = Normal measurement mode.
The display shows the measured induction dB/dt in mT/sec on the left-hand display, and the measured flux density B in nano Tesla on the right-hand display.

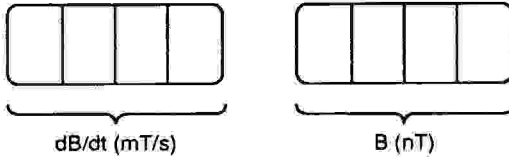

- 1 = Measurement mode with an initial display which presents Synchronisation channel with Sync Trigger Level and the Sync signal period time in msec. After approximately 1 second the display is as for mode 0.

Initial Display

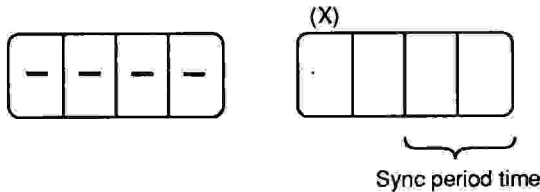

Result Display – after 1 second:

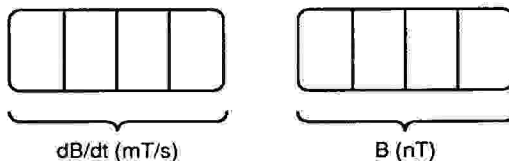

X Value	Sync Channel Selected	Trigger Level (%)
0	dBx_{peak}/dt	25
1	dBx_{peak}/dt	75
2	dBy_{peak}/dt	25
3	dBy_{peak}/dt	75
4	dBz_{peak}/dt	25
5	dBz_{peak}/dt	75

2 = Measurement mode induction and flux density peak values with minimum result truncation (2mT/s, 10nT) according to the MPR (I) recommendations.

Display as for mode 0.

3 = Measurement mode, which the sync frequency, in kHz is initially displayed on the right-hand display, followed 1 second later by the measured dB/dt and B_{peak} values.

Initial Display

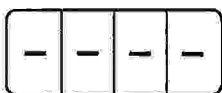

Sync Frequency (kHz)

Result Display – after 1 second:



dB/dt (mT/s)

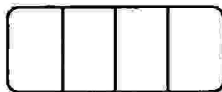

B (nT)

- 4 = Enables the expanded printout modes, in which the measured result and the directional components for both induction and flux density. This mode should only be used with external sync. Multiple measurement mode is not available when this mode is selected.

Display as for mode 0.

- 5 = Measures and displays the dominant frequency in kHz and the B_{rms} value according to the MPR II recommendation. For single measurements the measurement time is approximately three seconds per measurement.

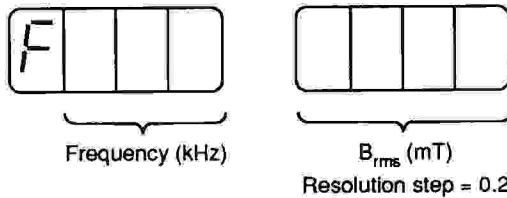

- 6 = Measures and displays the dominant frequency in kHz and B_{rms} values, but it is also provides an expanded print mode of B_{rms} , B_{rmsX} , B_{rmsY} , B_{rmsZ} .
 - 7 = Not used
 - 8 = Remote mode
 - 9 = Remote mode
- } (see Section 4)
- A = Special test mode, only used for service.

The default setting is mode 0.

3.4 Mains Voltage

Mains voltage can be set to either 220V (200 - 240V) or 110V (100 - 127V). The factory setting is 220V.

If the voltage setting is not correct for the available mains voltage just push the locking springs together and pull out the voltage setting plate. Pull out the lower fuse inset and re-insert it so that it displays the correct voltage. Insert the correct fuses for the set voltage and replace the setting plate.

IMPORTANT NOTE!

Different fuses are used for different voltage settings. Fuses must be 100 mA (slow) for 220V and 200 mA (slow) for 110V.

3.5 Loudspeaker Volume

There are two factory preset loudspeaker volumes (low - high). Normally the setting is at low volume.

If you want to change the volume level, turn off the mains power and remove the front panel. The two-pole cable contact of the loudspeaker is connected to a three-pole male contact at the bottom of the PC-board, see Fig. 3.2. Connection to the two left-hand poles gives low volume and to the two right-hand poles gives high volume. Check that the contacts are correctly connected and that the interface cable cannot be damaged when the front panel is replaced.

3.6 Serial Interface

The RS232C serial interface (P3) can be set-up with or without handshaking. Note that the factory setting is without handshaking. Figure 3.2 shows the strapping points, which are used to set-up the serial interface protocol.

The table on page 3.8 details the signal on each pin of the interface connector (P3) together with the strapping point which connects the signal to the MFM 1000.

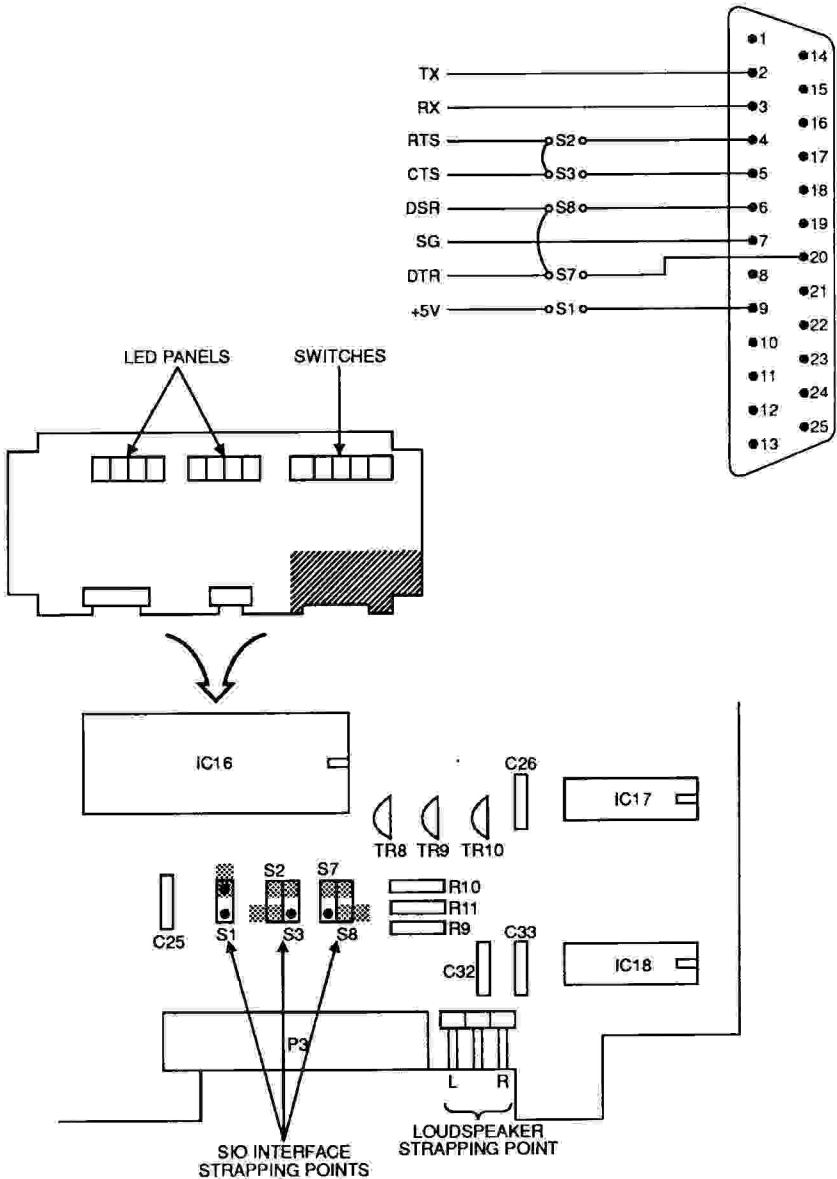

Fig. 3.2 Strapping Points on Digital PC Board (without Handshaking)

Serial Interface Pin (P3)	Name	I/O	Function
2	Tx	Out	Transmit data
3	Rx	In	Receive data
4	RTS (Request To Send)	Out	Always high
5	CTS (Clear To Send)	In	High, instrument clear to send
6	DSR (Data Send Ready)	In	High, instrument clear to receive
7	Signal Ground	—	
9	-----	Out	Strap S1 for +5V supply
20	DTR (Data Terminal Ready)	Out	Always high

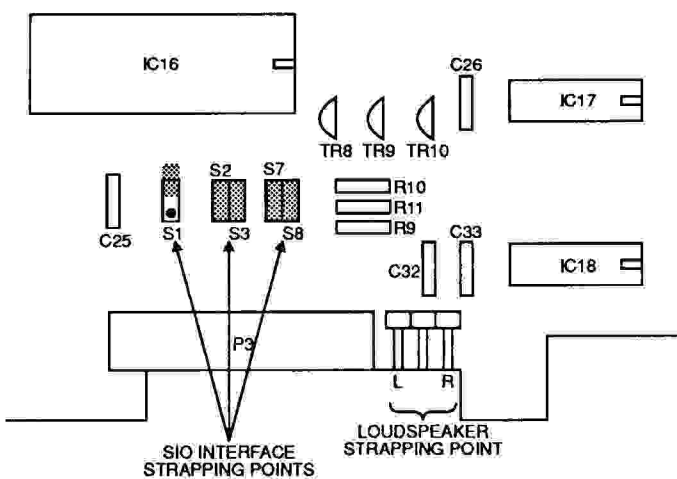

Fig. 3.3 Strapping Points on Digital PC Board (with Handshaking)

SECTION 4

OPERATING INSTRUCTIONS

4.1 Operating Panel

The operating panel on the left-hand side of the instrument has two 4 digit displays. The left-hand display shows either Sync Period Time, Sync Frequency or Induction while the right-hand display shows flux density, depending upon the selected mode. In Set-up mode the displays are used to indicate selected parameters (see Section 3).

When the MFM 1000 is switched on all segments in the displays and the beep are activated for two seconds.

On the right of the display panels are five operator keys with yellow LED indicators. The basic functions of the keys are:

- START – Pressing the key for a short time until a beep is heard initiates a single measurement. The “single” LED will be lit during measurement.
 - Keeping the key depressed until a second beep is heard initiates continuous measurement; if external sync has been selected. The “cont” LED will be lit during measurement.
- PRINT – Keeping the key depressed for longer than one second until a beep is heard starts a printout with a heading of selected parameters followed by the result(s).
 - The key is also used to empty the result buffer when MULTI mode is selected.
- MAX – When MULTI mode is selected, the maximum value stored in the result buffer can be displayed if this key is depressed. The last measured result can be displayed again if MAX is pressed again.
 - If MAX is selected during MULTI mode measurements, the maximum value stored in the result buffer is continuously displayed. When a new maximum value is found, a longer beep is given and the new value displayed.
- MULTI – A series of readings can be taken and stored in an internal result buffer. Press the 'MULTI' key so that the 'MULTI' LED is lit. This key has a toggling function, if the key is pressed again then 'MULTI' mode is de-selected. This mode is valid when measurement modes 0, 1, 2, 3 and 5 are selected.

- If the MULTI key is pressed while the result buffer contains stored results, then the 'MULTI' LED flashes to indicate that the result buffer must be emptied, before the multiple measurement mode can be exited. Press the PRINT key to empty the buffer and if a printer is connected obtain a printout.

SYNC - Internal or external synchronization is selected by pressing this key so that the "int" or "ext" LED is lit as appropriate. External synchronization is selected when the MFM 1000 is switched on. Normally external sync produces acceptable measurement results, if there is a dominant signal frequency. If there is no dominant signal to use as a synchronisation signal, then internal sync should be selected.

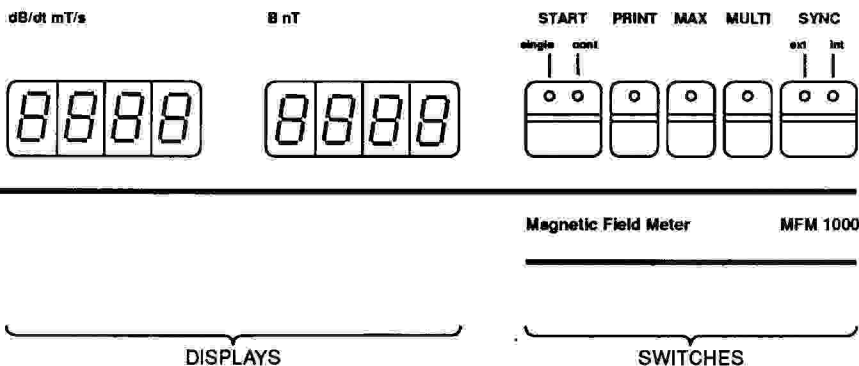

Fig. 4.1 Operator's Panel

4.2 Background Noise

Before the MFM 1000 is used, the local background noise should be checked. Position the MFM 1000 where it is intended to be used. Ensure that all equipment not used during measurements is switched off.

- Set the MFM 1000 to internal synchronization. Check that the "int" LED is lit.
- Initiate a single measurement, by pressing the START key. Note the readings on the display.

- If the peak values are greater than 2 to 3 mT/s or 10 nT, or the rms value is greater than 5 nT, then there are other sources producing magnetic fields. These will cause measurement accuracy problems and should be located and switched off. If it is not possible to eliminate the noise sources then select a 'quieter' place to site the MFM 1000 for the measurements.

4.3 Measurement Tools

Measurements made according to MPR I or II recommendations stipulate that readings should be taken at a defined distance. A distance measuring tool is included in the transport case. Refer to the MPR measurement application guide for detailed instruction of setting distances to those defined by the MPR recommendations.

4.4 Single Point Measurement

Single point measurement is performed by setting the MFM 1000 to external sync mode and pressing the START key. Measurement in progress is indicated by the "single" LED on the START key. If the MFM 1000 finds an acceptable sync signal a result will appear on the display within 2.5 seconds. Note the result or if a printer is connected, print it out.

Note: A number of measurement errors can occur during a measurement in which case an error code will be given on the display (see Section 7).

4.5 Multiple Point Measurement

When multiple point measurement is selected up to 80 readings can be taken and the calculated results stored in a result buffer. The present maximum value stored in the buffer can be continually displayed by pressing the MAX key so that the "MAX" key is lit. Multiple measurements are normally used to find maximum values at the points defined in the standard.

Multiple measurements are carried out as follows:

- Set the MFM 1000 to external sync mode with the SYNC key
- Set the MFM 1000 to multiple measurement mode with the MULTI key
- Perform repeated single measurements using the START key, as for single point measurement.

- If the MAX function is activated, only the present maximum value is displayed. New maximum values are indicated by a longer beep.

Note: The MAX function can be activated at any time during multiple measurements to find the present maximum value.

- When the sequence of multiple measurements is completed the result buffer is cleared by printing out the results using the PRINT key. If there is no printer connected then the PRINT key must still be used to clear the buffer. The MULTI function can only be de-activated if the result buffer is empty (if not, the LED will flash).

4.6 Continuous Measurement

Continuous measurements are used to follow changing magnetic induction. For example when trimming VDU compensating coils a continuous display of the calculated value is useful. External sync mode must be selected to carry out continuous measurements.

- Keep the START key pressed down while carrying out a complete single measurement to put the MFM 1000 into continuous mode. If measurement modes 0, 1, 2, 3 or 4 are selected, the left display will show dB/dt with an update rate greater than 4 times per second. If modes 5 or 6 are selected then the B_{rms} value is updated once a second. The internal beeper sound frequency will vary as a function of the measured value.
- To return to single measurement mode press the START key. A complete single measurement is made and single measurement mode is entered.

4.7 Printer Operation

Setting up the printer is detailed in Section 3.2. Printer operation is controlled by using the PRINT key.

- Pressing down the PRINT key for more than 1 second until a beep is heard enables a printout of a protocol heading followed by any stored results.
- A short activation of the PRINT key will give a printout of single or multiple results depending on the measurement mode selected.
- The yellow LED on the PRINT key indicates, when lit, that a printout is taking place.

If the PRINT key is pressed when no printer is connected then the result buffer will be cleared, and the stored data will be lost. Ensure that the data can be erased or connect a printer.

The format of the printouts are shown as examples below.

Example 1: Single measurement printout according to MPR I (with protocol header), measurement modes 0 and 2

```

Date: ..... Time: ..... Signature: .....
Brand: ..... Type: ..... Serial no: .....
Remarks: .....
.....
No dB/dt B No dB/dt B No dB/dt B No dB/dt B
(mT/s) (nT) (mT/s) (nT) (mT/s) (nT) (mT/s) (nT)
41. 54.
    
```

Example 2: Multiple measurement printout according to MPR I (without protocol header), measurement modes 0 and 2

No	dB/dt (mT/s)	B (nT)	No	dB/dt (mT/s)	B (nT)	No	dB/dt (mT/s)	B (nT)	No	dB/dt (mT/s)	B (nT)
1	41.	53.	2	83	108	3	123	163	4	164	217
5	203	269									

Maximum: 203 269
 Maximum stored measurement value (B_{peak})
 (dB/dt)_{peak}

Measurement number

Example 3: Single measurement printout according to MPR II (with protocol header), measurement mode 5

Date: Time: Signature:
 Brand: Type: Serial no:
 Remarks:

No	B (nT)	No	B (nT)	No	B (nT)	No	B (nT)
	190						

Measurement B_{rms} value

Example 4: Multiple measurement printout according to MPR II (without protocol header), measurement mode 5

No	B (nT)	No	B (nT)	No	B (nT)	No	B (nT)
	190						
1	190	2	152	3	115	4	76
5	38.0		190				

Measurement number

Maximum stored value

Measurement B_{peak} value

Example 5: Expanded printout according to MPR I, measurement mode 4

Date: Time: Signature:

Brand: Type: Serial no:

Remarks:

HF (kHz)	$\frac{dB}{dt}$ (.....)	$\frac{dBx}{dt}$ (..... mT/s)	$\frac{dBy}{dt}$ (.....)	$\frac{dBz}{dt}$ (.....)	B (.....)	Bx (..... nT)	By (.....)	Bz (.....)
120	40.	-7.	-1.	40.	53.	9.	1.	-52
↑ Sync frequency	↑ $(\frac{dB}{dt})_{peak}$	↑ $(\frac{dBx}{dt})_{peak}$	↑ $(\frac{dBy}{dt})_{peak}$	↑ $(\frac{dBz}{dt})_{peak}$	↑ (B_{peak})	↑ (Bx_{peak})	↑ (By_{peak})	↑ (Bz_{peak})

Measured value								

Example 6: Expanded printout according to MPR II, measurement mode 6

Date: Time: Signature:

Brand: Type: Serial no:

Remarks:

HF (kHz)	B (.....)	Bx (..... nT)	By (.....)	Bz (.....)
120	37.6	0.8	3.4	37.6

RMS values				

4.8 Remote Control

The MFM 1000 has a remote control facility, by connecting either a terminal or a computer. Section 3.3 describes how to set the instrument for remote control operation. To initiate measurements in remote mode the commands shown in the table overleaf should be sent from the computer to select the desired measurement mode. The measurement result is automatically sent back to the computer with the format shown in the table.

The data format for peak values is:

XXX ___ XXX CR LF (high range)

XX . ___ XX . CR LF (low range)

for rms values:

XXX ___ XXX CR LF (high range)

XXX . ___ XX . X CR LF (low range)

where _ = space, X = number digit, and . = low range selected.

The leading zero's in each result value are represented by space. If a [.] is present after the result value then low range was selected, when there is no [.] then high range is selected.

If an error occurs during a measurement cycle an error code is displayed on the control panel (see Section 6) and generated to be sent to the computer. The error code format is:

E [X] CR LF

where X = error code number (see Section 6).

Command Character	Measurement Mode	Result Format
S	Mode 0, external sync.	$\left(\frac{dB}{dt}\right)_{peak} (B_{peak})$ CR LF
T	Mode 0, internal sync.	$\left(\frac{dB}{dt}\right)_{peak} (B_{peak})$ CR LF
R	Mode 4, external sync.	(Frequency) $\left(\frac{dB}{dt}\right)_{peak} \left(\frac{dBx}{dt}\right)_{peak}$ $\left(\frac{dBy}{dt}\right)_{peak} \left(\frac{dBz}{dt}\right)_{peak}$ $(B_{peak}) (B_{x_{peak}}) (B_{y_{peak}})$ $(B_{z_{peak}})$ CR LF
A	Mode 5, external sync.	(Frequency) (B_{rms}) CR LF
B	Mode 5, internal sync.	(Frequency) (B_{rms}) CR LF
C	Mode 6, external sync.	(Frequency) $(B_{rms}) (B_{x_{rms}})$ $(B_{y_{rms}}) (B_{z_{rms}})$ CR LF

SECTION 5

TECHNICAL DESCRIPTION

5.1 Antenna

The antenna is shown in simplified form in Fig. 5.1 and consists of three perpendicularly aligned windings with a common centre. Each winding consists of ten turns of insulated wire with a winding area of 0.01m^2 . Spacing between the turns and screen is selected so that self capacity effects do not give rise to resonance peaks at or near to the frequency range of interest. There is a separate electrostatic screen around each of the windings.

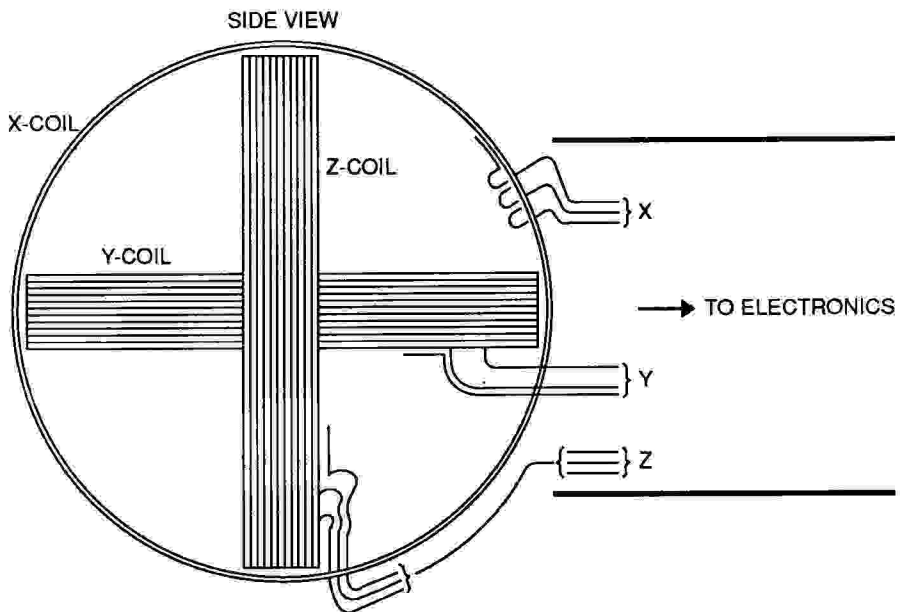

Note:
Electrostatic screen
not shown.

Fig. 5.1 Antenna

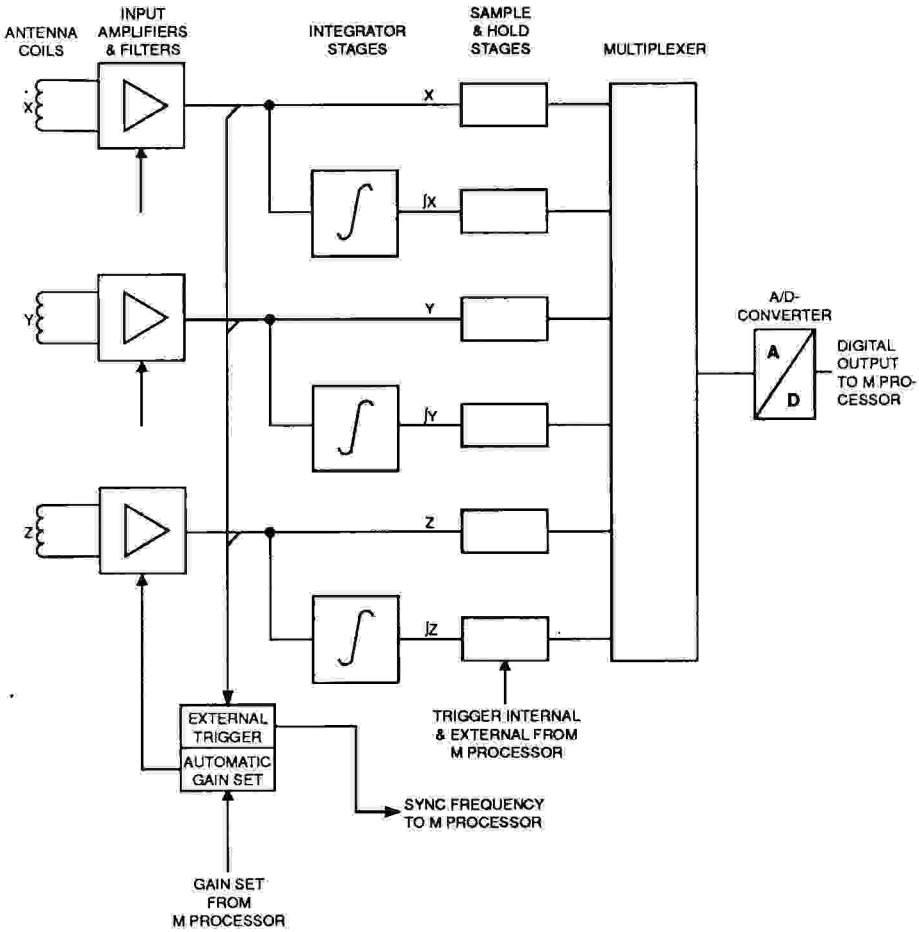

Fig. 5.2 Simplified Block Diagram

5.2 Electronics

The MFM 1000 has two printed circuit boards. The microcomputer and the digital electronics are placed on the panel side of the MFM 1000 while the analogue electronics are situated on the rear side. Fig. 5.2 is a schematic diagram of the analogue electronics which have the following main functions:

- Input amplifiers for each antenna coil with a fixed amplification and a low-pass filter with a cut-off frequency of 400 kHz
- Four-pole high-pass filters with cut-off frequency 2 kHz
- Amplifier stages with automatically switchable amplification
- Integrator stages with fixed time constant
- 'Sample and hold' circuits to allow synchronous sampling of the instantaneous value of induction and its time integral
- An analogue multiplexer followed by a 12 bit A/D converter.
- Power supply generation

The digital PC-board has the following main functions:

- Microcomputer with peripheral circuits (EPROM, RAM, EEPROM) to control data acquisition and calculation
- Two 4-digit displays of LED-type for presentation of B (in nT), $(dB/dt)_{peak}$ (in mT/s), B_{rms} (nT) and synchronisation frequency (kHz).
- Operator control keys and their interface
- Printer interface for serial communication with a printer or a host computer (RS232, selectable baud rate).

5.3 Measurement Principle

The time derivative of magnetic flux density, **Induction**, is measured by measuring the voltage induced into a sensing coil of known characteristics. Integration in time of the measured voltage permits computation of the **magnetic flux density**. These quantities are vector quantities, which vary with time in both magnitude and direction. The maximum values of the vector magnitudes are normally calculated.

The magnitude of the resultant for magnetic induction is calculated using the recorded instantaneous values of the induced voltages in the three orthogonally positioned coils with common centre point by quadratic addition and extraction of roots. Calculation of the magnitude of the resultant for flux density is carried out in a similar fashion, after simultaneous but individual integration of the three induction voltages. It should be noted that integration of the total magnitude for induction does not give the total magnitude for flux density. Therefore the integration is carried out individually for each coil, before total flux density is calculated.

A combination of analogue and digital measurement techniques is used to measure the largest resultant vector at the antenna location of induction and flux density. The measured signal from each sensing coil is amplified, filtered and integrated using an analogue amplification technique. The signals obtained in this way from the three coils are sampled, synchronized in time with a variable delay from a suitable synchronizing signal produced by the VDU. The delay is varied in stages, so that a complete cycle of the measured signal can be examined. In this way, for each sampling point, six values are obtained which correspond to the instantaneous values of induction and flux density from the triaxially aligned sensing coils.

The six digital results obtained are squared and added. The maximum square root of these sums is proportional to the magnitude of the resultants for induction and flux density. After rescaling for amplification and the integrator time constant, the appropriate results are presented on two displays after approximately two seconds from start of measurement. The magnetic flux density result is presented as either a peak value or as an RMS value, depending on the selected measurement mode.

In continuous mode more than four measurements will be performed per second when the B_{peak} value mode is selected. When the B_{rms} mode is selected, one measurement per second is made, with a resolution of 0.2. This mode will always start with a complete single point measurement and then keep track of the maximum result by sampling around the previous maximum result. Continuous mode is used during the adjustment of the VDU compensating coils to minimize the total field to acceptable limits. An audio tone in the range 250 - 3000 Hz, as a function to dB/dt, can be activated to simplify adjustment.

5.4 Specifications

Range dB/dt:	50 or alternatively 500 mT/s (automatic ranging)
Accuracy:	Better than 2% of range
Range B_{peak} :	200 or alternatively 2000 nT (automatic ranging)
B_{rms} :	140 or alternatively 1400 nT (sine wave)
Accuracy:	Better than 3% range
Frequency range:	2 kHz - 400 kHz (filter characteristics specified in the standard)
Measurement time:	B_{peak} : 2.5s (ext. sync.) 4.5s (int. sync.) More than 4 measurements per sec. in continuous mode B_{rms} : 3s, 1 measurement per sec. in continuous mode
Power voltage:	220V/110V, $\pm 15\%$, 47 to 63 Hz
Power:	15 VA
Weight:	2.6 kg
Size:	Length: 500mm Height: 200mm Width: 100mm

SECTION 6

ERROR CODES

6.1 Measurement Errors

During measurement using external sync mode, a number of errors can occur due to problems related to the sync signal.

Error Code	Reason
E 1	Sync period <7 μsec
E 2	Sync period >70 μsec
E 3	Sync signal period unstable
E 4	Sync signal disappeared >1ms during measurement
E 5	Sync signal noisy during measurement
E 6	Sync signal period changed during measurement
E 7	Sync signal too small for external sync

If an error of this type is related to environmental noise spikes, then the measurement should be repeated. If this is unsuccessful try to remove any electronic device that may be causing noise. Note that a switched power supply unit may trigger the MFM 1000 at the same frequency as the field being measured. If nothing helps, use the internal sync for measurement and compensate for the influence on the result caused by the noise.

6.2 Operational Errors

Error Code	Reason	Action
E 10	Printer handshake on the serial interface too slow.	Check the printer, printer cable and the baud rate setting.
E 11	Keyboard disabled, remote mode.	This error occurs if an attempt is made to use the panel keys in remote mode. For details regarding mode programming see Section 3.1.

6.3 Memory Errors

Errors of this type can occur at the internal power up test of the MFM 1000.

Error Code	Reason
E 21	Checksum error in PROM
E 22	RAM error
E 23	EEPROM error
E 24	Incompatible hardware and software

An instrument service will be required to overcome the problem, contact Combinova AB for assistance.

6.4 Software Errors

If an error of this type occurs, a software error has taken place.

Error Code	Reason
E 31 - E 36	Software errors

A program modification is normally needed to overcome the error. Contact Combinova AB for assistance.

Quick Reference Guide

This is a quick reference guide to operate the MFM 1000 instrument. Refer to the manual for more detailed information.

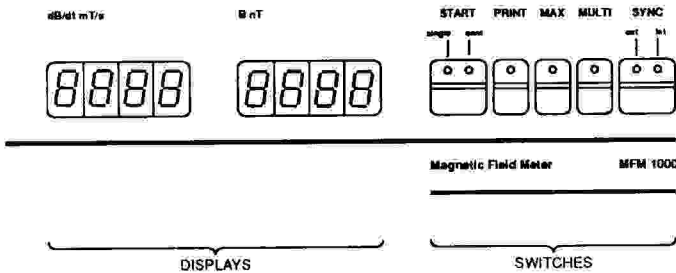

Control Panel

Operation	Action	Display
Check background noise	SYNC to "int". Press START	Result values should be $\left. \begin{array}{l} < 2\text{-}3\text{mT/s} \\ < 10\text{nT} \\ < 5\text{nT} \end{array} \right\} \begin{array}{l} \text{peak} \\ \text{rms} \end{array}$
Single point measurement	SYNC to "ext". Press START	See measurement mode selection
Multiple point measurement	SYNC to "ext". Press PRINT – to empty result buffer. Press MULTI. Press START	See measurement mode selection
Continuous measurement	SYNC to "ext". Press START until a beep is heard. Press START again to stop measurement	See measurement mode selection
Display maximum result only (in multiple and continuous modes)	Press MAX. Press MAX again to display last measured result	Maximum value displayed if new maximum value found beep is given

Set-up

Enter programming mode by pressing START and SYNC when switching on the instrument. Four values will appear on the right-hand display A B C D, according to the last settings made in programming mode. Digit A will flash. To alter a value use the START key. To select the next digit use the SYNC key. To store the selected parameters and exit mode press the SYNC key twice after selecting digit D.

(A) Language

- 0 = English
- 1 = Swedish

(B) Printer Format

- 0 = No printer used
- 1 = 48 lines/page
- 2 = 66 lines/page
- 3 = 70 lines/page
- 4 = 72 lines/page

(C) Baud Rate

- 0 = 300 baud
- 1 = 600 baud
- 2 = 1200 baud
- 3 = 2400 baud
- 4 = 4800 baud

(D) Measurement Mode

Mode	Left Display	Right Display
0. Normal measurement	dB/dt (mT/s)	B (nT)
1. Normal measurement with sync select and sync period time display – initial display	—	Trigger channel – sync period (msec)
– result display	dB/dt (mT/s)	B (nT)
2. Induction and flux density peak values with minimum result truncation	dB/dt (mT/s)	B (nT)
3. Normal measurement with sync frequency display – initial display	—	Sync frequency (kHz)
– result display	dB/dt (mT/s)	B (nT)
4. Expanded printout mode	dB/dt(mT/s)	B (nT)
5. Measurement dominant frequency and B_{rms} value	Frequency (kHz)	B_{rms}
6. Expanded print mode of frequency, B_{rms} and component rms values	dB/dt (mT/s)	B_{rms} (nT)
7. Not used	—	—
8 and 9. Remote mode	—	—
A. Special test mode only used for service		